



Installation Guide of TB19 technology flooring

INTRODUCTION

Please read all instructions carefully before installation. Improper installation may void the warranty.

PRODUCT USE

Parquets Alexandra TB19 products can be installed above, on or below grade. Parquets Alexandra TB19 products may either be glued down over plywood/OSB or concrete subfloor or simply nailed/stapled down over plywood/OSB floor, using a specially designed hardwood floor stapler or nailer or floated over a recommended membrane. Most wood species can also be installed over subfloor equipped with radiant heat systems.

INSTALLER AND OWNER RESPONSIBILITY

Prior to installation, the installer and owner must ensure that the work environment and subfloors meet or even exceed minimal specifications listed in this installation guide.

Standard trade practice allows for up to a 5% margin of error for natural imperfections and manufacturing defects. Prior to installation, the installer and owner should conduct a final inspection of grade, color, manufacturing and finish quality of boards to ensure that the floor conforms to purchased product.

Once installed, every board is considered as having been accepted by installer and owner, even if owner is absent at time of installation. When ordering hardwood flooring, it is recommended to add to the square footage needed an allowance for cutting waste.

WARRANTY

MIRAGE* guarantees the original purchaser the following warranties and the ones stated in the Parquets Alexandra Warranty Certificate for all flooring purchased after January 20th, 2023.

Structural lifetime warranty

For the glued down and nailed/stapled down installation, relative humidity must always be maintained within a range of 25% and 80%. For the floated installation, it must be maintained between 30% and 60 %.

Finish warranty

MIRAGE guarantees the original purchaser that the finish applied on its Parquets Alexandra TB19 floor will not wear through or separate from the wood for a period of:

- **Thirty-five (35) years** from the date of purchase, when used under normal residential traffic conditions;
- **Three (3) years** from the date of purchase, when used under light commercial conditions.

Surface wear must be readily visible and cover at least ten percent (10%) of the total flooring surface area.

Disclaimer

- The nature of Character grade flooring explains the appearance of certain characteristics visible at time of purchase or developing over time, including pronounced color variations, open and closed knots, mineral streaks, cracks, surface holes, and other character or milling marks are part and parcel of this effect.
- Some distinctive marks may become prominent over time due to changes in the environment.

For more information on the warranty, consult the Parquets Alexandra Warranty Certificate. In the event of a discrepancy between the information in the Installation Guide and the Parquets Alexandra Warranty Certificate, the latter shall prevail.

FLOOR CARE PREVENTION TIPS

For information on floor care prevention, consult Parquets Alexandra's Residential Maintenance and Warranty Certificate on our website parquetsalexandra.com.

MIRAGE, Technical Service Department

1255, 98th Street, Saint-Georges (Quebec) Canada G5Y 8J5

Tél. : 418 227-1181 – 800 463-1303 – Fax : 418 227-1188

Or by email: technical@miragefloors.com

* MIRAGE, our renewed corporate brand, embodies the quality and care found in our prestigious brands such as Mirage Hardwood Floors, Vintage Hardwood Floors, Ten Oaks and Parquets Alexandra. Our legal entity is called Boa-Franc G.P.

TOOLS

RECOMMENDED TOOLS, MATERIAL AND ACCESSORIES

- Vacuum cleaner or broom
- Scraper
- Leveling bar
- Level
- Leveling compound (optional)
- #20 grit sand paper (optional)
- Wood and/or concrete moisture meter
- Miter saw
- Handsaw
- Security glasses
- Trowel
- Claw hammer
- Nail punch
- Pry-bar
- Square 16" x 24"
- Measuring tape
- Chalk line
- Reversing tongue (optional)
- Repair kit
- Maintenance kit available at parquetsalexandra.com

Glued down installation

Refer to our [Technical Newsletter #23](#) in the Documentation section at parquetsalexandra.com to know more about the minimum criteria regarding recommended adhesives.

- Trowel recommended by adhesive manufacturer as tooth size is important for ensuring optimal strip adherence to subfloor.
- 2" (50 mm) concrete nails and 1" x 3" x 8' (25 mm x 75 mm x 245 cm) laths for first-row holding block.
- 3M blue adhesive tape or easily removable equivalent.
- 100 to 150 lbs (45 to 68 kg) pound roller.
- Remover towels for hand and tool cleaning.
- Adhesive cleaner.
- Recommended membrane if necessary. Please refer to our [Technical Newsletter #26](#) at parquetsalexandra.com.

Stapled/nailed down installation

Please refer to our [Technical Newsletter #30](#) in Documentation section at parquetsalexandra.com.

- Pneumatic staplers/nailers.
- Power drill and 3/32" (2 mm) bit
- Finishing nails: 2-1/2" po (63 mm).
- Flooring screws.

Floated installation

- Recommended membrane ([Technical Newsletter #20](#)).
- Use a wood adhesive thick enough and that remains flexible to ensure proper adhesion such as:
 - Recognized carpenter glue meeting CSA 0112.4 (do not use multi-purpose glue).
 - Wood Adhesive Type 2 (carpenter glue, enhanced PVA glue, etc.). Please refer to the adhesive manufacturer for the mechanical properties of the glue.
- Waterproof adhesive tape (3M tape).

Prefinished accessories such as reducers, stair nosings, etc. are available from your Parquets Alexandra dealer.

Note: MIRAGE cannot be held responsible for any floor damage resulting from use of inadequate fasteners or adhesive, differing from those recommended. All the installation material must be at the recommended room temperature prior to the installation ± 22 °C (± 72 °F).

PREPARATION

HANDLING AND ACCLIMATIZATION

Prefinished hardwood floor installation requires a little more time and precaution than unfinished flooring; handle with care to avoid board surface and finish damage.

PRE-INSTALLATION CHECK LIST

Basic requirements

- Hardwood floor installation should be the very last step of any construction or renovation project.
- Prior to installation, heating system must be in operation, and room temperature must have been maintained at ± 72 °F (± 22 °C) for at least one week.
- To avoid any moisture-related damages, subfloor must be dry and basement well ventilated.
- For below grade installation, ensure that foundations, concrete slab or any adjacent objects are thoroughly leak proof.

- **Relative humidity must be maintained around $\pm 45\%$ at all times.** For glued down and nailed/stapled down installation, relative humidity must always be maintained within a range of 25% and 80%. For floated installation, it must be maintained between 30% and 60%.

Radiant heat performance:

Refer to [Technical Newsletter #31](#) in the Documentation section at parquetsalexandra.com for recommendations.

Subfloor moisture level check

Wooden subfloor: Wooden subfloor moisture reading must not exceed 12% and differential between boards and subfloor must be less than 4%. Wood moisture meters are available from your Mirage Authorized dealer. If moisture reading is too high, postpone installation, find moisture source and correct it if needed. Raise heat and increase ventilation until proper conditions are met.

Concrete subfloor: Prior to installation, concrete subfloor should preferably be 45 to 90 days old, 30 days being the absolute minimum. Concrete moisture meter must be used to check subfloor moisture level; if the result exceed 3.5%, calcium chloride test must be performed. **The concrete subfloor moisture content must not exceed 3 lbs / 1,000 sq. ft. /24 hours.** If the reading exceeds 3 lbs, use a complete moisture-proofing system (sealer and adhesive) compatible with the selected adhesive. Please refer to the manufacturer's documentation for the selected products for information on their warranty, product limitations, and installation recommendations.

Material Acclimatization: Keep boxes of wood in room where flooring is to be installed for at least 24 hours before installation.

Owner and installer are solely and jointly responsible for pre-installation subfloor moisture level check and must ensure that all conditions and/or specifications listed in this guide have been thoroughly met prior to installation of hardwood floor.

SUBFLOOR PREPARATION

Stapled down installation requires minimum 5/8" (16 mm) plywood, or 23/32" (18 mm) OSB chipboard subfloor.

- **Sound:** Wooden subfloor must be securely screwed down to joists to prevent any movement or squeaks. Thoroughly inspect and replace existing floor or subfloor that shows evidence of water damage or structural weakness. Snow and rain during construction could affect negatively some properties especially on OSB. Concrete subfloor must be just as structurally sound before installing hardwood floor and should be rated with a minimum compressive strength of 3000 psi.
- **Flat:** For a glued or stapled/nailed installation, subfloor surface must be flat and maximum tolerance is 3/16" (5 mm) per 10' (3 m). For floated installation, maximum tolerance is 3/32" (2 mm) per 7' (2 m). If necessary, flatten down any irregularities, using #20 grit paper, and correct any uneven spots.
- **Dry:** Subfloor must be dry and within moisture reading specs.
- **Clean:** Vacuum and free subfloor from any debris or obstacles such as cleats, nail heads, dried glue or any other material.

PREPARATION BEFORE FLOORING INSTALLATION

- Sketch installation to avoid surprises.
 - Decide starting point or wall.
 - Decide layout angle.
- Remove any baseboard, doorsill and old floor covering if necessary.
- Trim bottom of the doorstop with handsaw to insert boards underneath.
- To enhance the floor's look, use several boxes at once and mix boards to ensure variations in color, shade and length.
- Start by selecting the boards that will best go with the transition moldings.

GLUED DOWN INSTALLATION

GLUED DOWN INSTALLATION INSTRUCTIONS (illustration #1 at page 8)

Wear security equipment and maintain a safe environment at all times.

Step 1 – Starting point

- Using a chalk line, make a starting mark **A** parallel to starting wall **B**. The distance from the parallel wall and the starting line is based on the board widths. See the table below.

Boards widths	Distance between wall and starting line (working area)
5" (127 mm)	35-1/4" (895 mm)
6-1/2" (165 mm)	32-11/16" (832 mm)

- Working area **C** between starting wall and starting line, will be last floor section laid. Above measurements account for ideal fit, so that it will not be necessary to rip saw finishing board row, while allowing for required 1/4" (6 mm) expansion gap **D**.
- Holding block **E** must be nailed down alongside starting line inside working area to secure starting row in place.

Step 2 – Adhesive application ([Technical Newsletter #23](#))

For optimal adhesive application, work trowel **F** in circular motion at 45° angle; adhesive left on floor by trowel teeth is just the right amount. (One gallon covers about 45 to 50 sq. ft. depending on manufacturer's specs. See container.)

Note: Only cover surfaces that can be reasonably laid in two hours, since adhesive may dry too quickly and not stick properly. Reaction time may vary from one adhesive to another and may also be affected by room temperature and relative humidity (see manufacturer's specs on container).

Step 3 – Board laying

- It is very important that installation be started straight and square.
- Carefully select boards. As needed, cut boards that appear different or move them to a less visible location.
- Laying from working area, leave 1/4" (6 mm) gap alongside left wall which is perpendicular to starting line, prop tongue side against holding block and press first board **G** down into adhesive.
- Install subsequent boards **H**, proceeding from left to right until ready to trim first-row end board.
- To minimize trim waste, select board long enough **I** for row end, so that remaining trimmed end may be used to start subsequent row. Leave 1/4" (6 mm) gap at end of each row **J**.
- First board of second row must be at least 6" (150 mm) shorter or longer than that of first row. Cross joints must be staggered by at least 6" (150 mm) from one row to the next. Avoid lining the joints up or having them follow too regular a pattern (illustration #4).
- Insert tongue end into board groove, lower board as close as possible to adjacent one, slide tongue into groove and press board down.
- Proceed the same way for subsequent rows.
- Once main part of floor has been laid, remove blocking laths from working area and complete installation in the same manner. Use pry bar to fit last row of boards into place and be sure to leave minimum required 1/4" (6 mm) expansion gap.

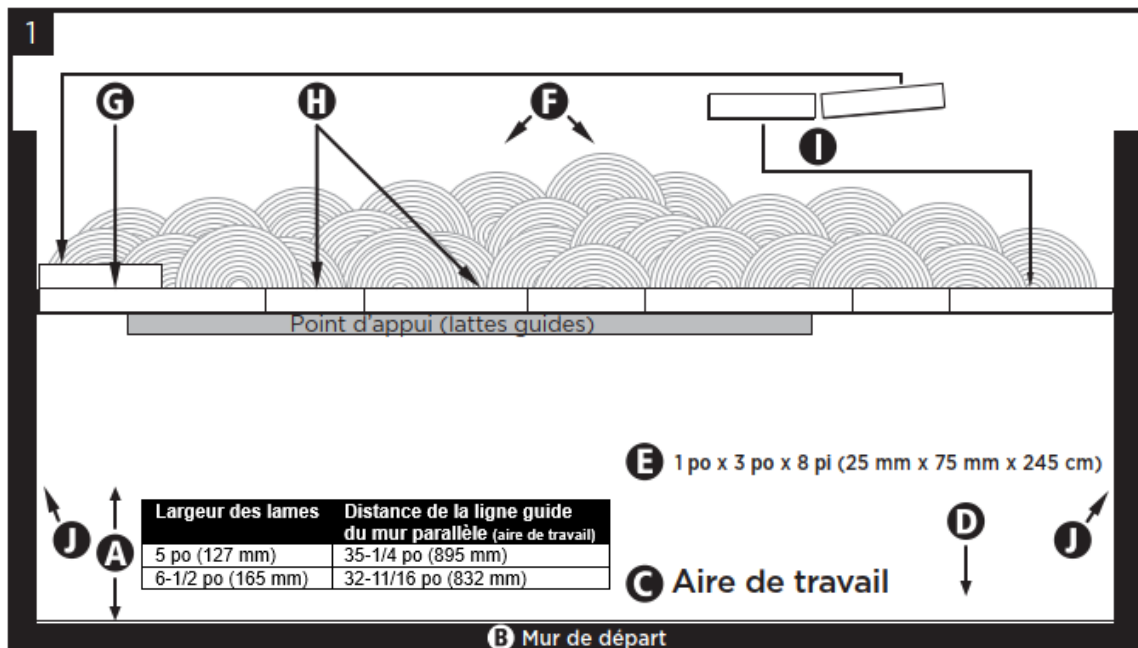

Notes:

- When used, acoustic underlayment must be glued down over subfloor prior to gluing down boards using the same recommended adhesive ([Technical Newsletter #26](#)).
- Extremely precise board milling may require use of tapping block for better tongue and groove fit.
- Row to row installation requires that no glue seeps into grooves at any time for perfect tongue and groove fit.
- Avoid getting adhesive on hands to minimize clean up. **Wipe any adhesive from floor right away**, using solvent and towels. Use paint thinner or lighter fluid to remove stubborn adhesive spills.
- To maintain boards in place and avoid board movement causing gapping during installation, use 3M blue adhesive tape.
- For better board contact with adhesive, it is recommended to use adhesive manufacturer's recommended pound weight roller (usually 100 to 150 lbs / 45 to 68 kg required) over laid floor section **before adhesive dries**. Use roller's protective padding to avoid damage to floor surface.

Step 4 – Accessories installation

- If applicable, install transition moldings, stair nosings and reducers.
- If applicable, reinstall baseboards and quarter rounds, making sure to nail them only to walls and not to floor (to allow free floor movement).

Step 5 – Post-installation

- Wait 24 hours before moving furniture back into place or allowing heavy traffic.
- Set a few boards aside in case of future repairs.
- When installation is completed, vacuum floor thoroughly, spray light mist of hardwood floor cleaner on terry cloth mop and clean floor.

STAPLED/NAILED DOWN INSTALLATION

STAPLED DOWN INSTALLATION (illustrations #2 and #3 at page 11)

Wear security equipment and maintain a safe environment at all times.

Step 1 – Starting point

- Using a chalk line, make a starting mark parallel **A** to starting wall. The distance from the parallel wall **B** and the starting line is based on the board widths. See the table below:

Boards widths	Distance between wall and starting line
5" (127 mm)	5-1/4" (133 mm)
6-1/2" (165 mm)	6-3/4" (171 mm)

Step 2 – Boards laying

- It is very important that installation be started straight and square.
- Carefully select boards. As needed, cut boards that appear different or move them to a less visible location.
- Align first board tongue side with starting line **A**, grooved side facing starting wall; leave 1/4" (6 mm) gap from right **E** side wall which is perpendicular to starting line. Drill and nail board vertically **C** as close to wall as possible to hide nail heads when baseboards and quarter rounds **D** are in place. Install subsequent boards from right to left until ready to trim row end board.
- To minimize trim waste, select board long enough for row end, so that remaining trimmed end may be used to start subsequent row. Leave 1/4" (6 mm) gap at end of each row. **E**.
- First board of second row must be at least 6" (150 mm) shorter or longer than that of first row. Cross joints must be staggered by at least 6" (150 mm) from one row to the next. Avoid lining the joints up or having them follow too regular a pattern (illustration #4).
- Since wall proximity prohibits use of stapler, use finishing nails approximately every 4" (100 mm) alongside tongue **F** for first few rows, and punch nail heads down.
- Subsequent rows must be installed the same way, using the stapler. Staple boards every 4 to 6" (100 to 150 mm), and must have a fastener (staple) between 2 and 3" (50 and 75 mm) on the ends of each board.
- Because of wall proximity, installation of last 4 or 5 rows is identical to installation of first few rows. You might have to rip-saw last row of boards to leave required 1/4" (6 mm) gap **B** alongside finishing wall.

Note:

- Extremely precise board milling may require use of tapping block for better tongue and groove fit.

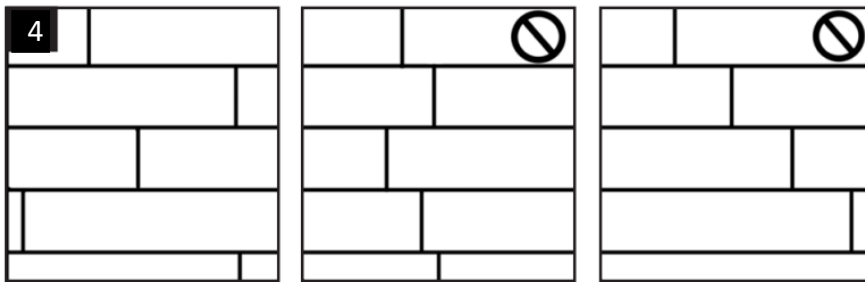
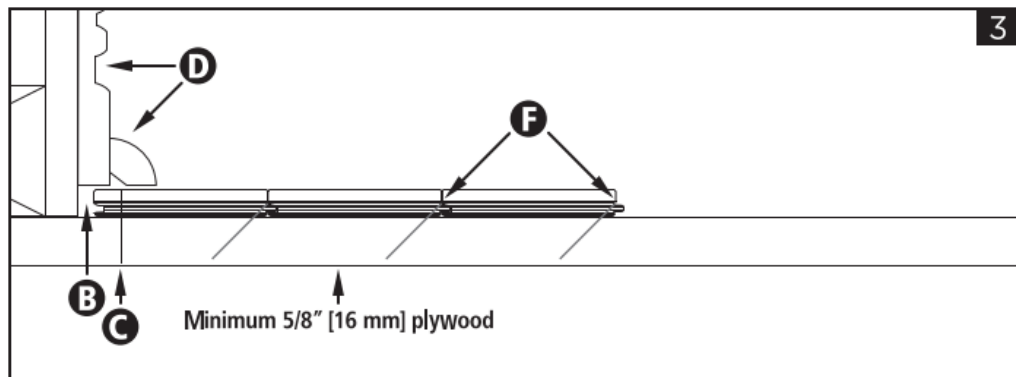
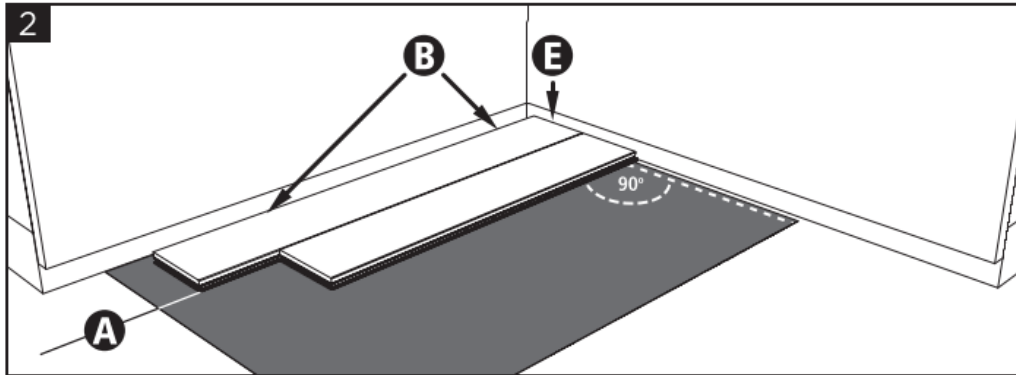

Step 3 – Accessories installation

- If applicable, install transition moldings, stair nosings and reducers.
- If applicable, reinstall baseboards and quarter rounds, making sure to nail them only to walls and not to floor (to allow free floor movement).

Step 4 – Post-installation

- Wait 24 hours before moving furniture back into place or allowing heavy traffic.
- Set a few boards aside in case of future repairs.
- When installation is completed, vacuum floor thoroughly, spray light mist of hardwood floor cleaner on terry cloth mop and clean floor.

PNEUMATIC STAPLER TIPS

Warning

To avoid damaging boards during installation:

- Ensure that stapler/nailer base plate remains clean and free from nicks at all times.
- When stapler/nailer is not being used, place on piece of plywood or cardboard, but never directly onto floor.
- Ensure that stapler/nailer base sits flat on floor and plumb against tongue before stapling board down.
- **Check base plate condition and proper operation of stapler/nailer regularly.**
- Set and check air pressure regularly on subfloor types requiring specific air pressure settings.

FLOATED INSTALLATION

Floated installation

Step 1 – Underlayment ([Technical Newsletter #20](#))

A recommended underlayment is required when Parquets Alexandra TB19 is floated. For more details, please contact our Technical Service Department at 1-800-463-1303.

- Cover all of the subfloor as well as the base of the walls (approx. 2" (51 mm)) with the recommended membrane. Place the membrane in the opposite direction to the boards, which is to be installed without overlapping.
- Some recommended underlayments include a self-adhesive flap. Use waterproof tape to attach the strips on the short side.
- Consult the documentation that comes with the recommended membrane for installation instructions.

Step 2 – Starting point

If a room exceeds 40' (12 m) width or 66' (20 m) length, use a "T" molding to increase the space required for the expansion gap. In irregularly shaped spaces (L, F, T, or U shaped), use a "T" molding for intersections (Illustration A).

- While facing the wall, start on the left corner leaving a gap at both walls with the tongue facing you. Leave a 1/2" (13 mm) gap between the wall and the edge of the board.
- Side joints only should be glued using type 2 wood adhesive. No glue should ever be applied to end joints. (Please refer to the adhesive manufacturer for the mechanical properties of the glue). Apply the glue on the top corner of inside groove only. Flip the board, as shown on the picture, to make it easier.
- Moving right, put the next board in place. Sliding vertically, insert the end tongue into the end groove of the first board. Continue in this way until it is time to cut the last board to finish the first row.
- The board chosen to finish the first row should be long enough to start the second row with the trimmed end, so as to minimize trim waste.
- Leave a gap for the board to expand in all directions.
- Start the second row with the trimmed end of the board. It should be at least 6" (150 mm) longer or shorter than the board used in the first row.
- Cross joints must be staggered by at least 6" (150 mm) from one row to the next. Avoid lining the joints up or having them follow a too regular pattern (Illustration #4).

- It is recommended to use 3M blue tape to hold the flooring in place (X pattern to prevent shifting) until the adhesive has completely dried. Straps can also be used to hold the flooring in place.
- **Any excess glue should be cleaned off the surface of the floor immediately as flooring is being installed.**
- As the floor can still be moved after the third row has been installed, it is recommended that you measure and realign with buffers, if necessary.
- The boards on the last row must be at least 1-1/2" (38 mm) wide. Remember to leave a gap for the expansion space.

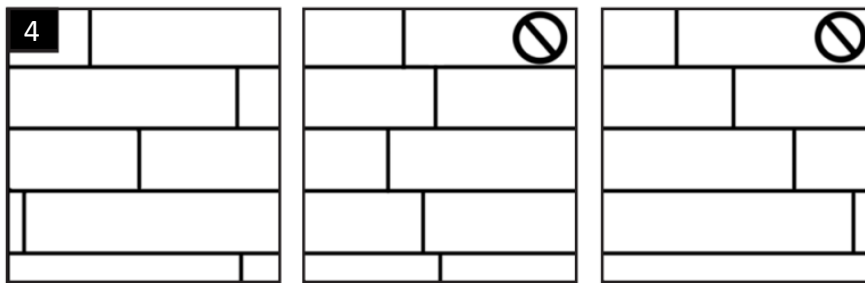
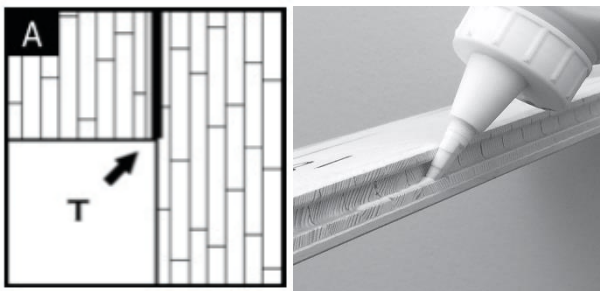

Step 3 – Accessories installation

- If applicable, install the transition moldings, stair nosings and reducers.
- Remove the buffers.
- Reinstall the moldings and quarter rounds as required, through the underlayment. Nail them to the walls and not to the floor, so that the floor can move naturally.
- Cut the underlayment that goes beyond the moldings.

Step 4 – Post-installation

- Set a few boards aside in case future repairs are required.
- When installation is completed, vacuum the floor thoroughly, spray a light mist of hardwood floor cleaner on a terry cloth mop and clean the floor.